

# RESPA®-SD/SD<sup>2</sup> & SDX/SDX<sup>2</sup> FILTER CHANGE & MAINTENANCE

## WHEN TO REPLACE FILTER:

Replace filter when the cab pressure sensor light comes on and remains on even after the cab door is closed and the machine is turned on. (Refer to Pressure Sensor Installation Manual)

Change the RESPA filter after every 1000 hours of operating time, even if the pressure monitor does not alert and there are no noticeable changes.

**Sy-Klone recommends the use of a Pressure Monitor System with all installations.**

## FILTER REPLACEMENT:

See video on how to change RESPA filter at [www.sy-klone.com](http://www.sy-klone.com) in Video Library.

1. Work in a clean covered area to reduce operator and HVAC exposure to harmful dust.
2. Wear appropriate personal protection equipment such as gloves, mask, and coverall to protect against contaminants.
3. Disconnect flex hose from RESPA air outlet. Plug or cover end of hose to prevent contaminants from entering the HVAC system.
4. Depending on your model of SD, either loosen 4 bolts or unlatch the six clips which hold the lid in place.
5. Once the lid is removed, examine the rubber gasket that seals the lid to the filter housing. If the rubber gasket is torn or missing replace it.
6. Remove the filter retention clip:
  - a. If your lid installs with 4 bolts (unit with flat lid), simply pull the white filter clip out of the box.
  - b. If your lid is held on by 6 clips (unit with rounded lid), remove filter clip by pressing clip towards the filter's outer ring, then by lifting the clip out by pulling up on tab. **DO NOT DISCARD THE CLIP!** You will need this clip to reinstall the new filter.
7. Remove the filter by applying pressure in a motion away from the outlet of the filter box. The filter is held firmly by the rubber "O" ring seal and will require gentle but firm pressure to remove.
8. Bag and seal used filter element and dispose of according to local regulation.
9. Remove loose debris using suitable vacuum unit and clean rags - never use compressed air.
10. Lubricate O-ring seal on filter element (lubricant provided with new filter). Place in housing with open end of filter towards outlet, lift slightly with fingers to align with inside of outlet and shift towards outlet until you feel positive abutment and the O-ring seats into the groove inside the RESPA outlet.
11. Reinstall filter retention clip:
  - a. If your lid installs with 4 bolts, then install the new clip provided the new filter. Simply snap clip in place.
  - b. If your lid is held on by 6 clips, reinstall the original filter clip by pushing filter retention clip into place. Clip will snap and lock into place.
12. Replace the RESPA lid.
  - a. If your lid installs with 4 bolts (flat lid), tighten screws by hand to seal RESPA Unit.  
**NOTE:** Tighten 4 bolt lid **by hand** to seal unit. Do not use power tools!
  - b. If your lid is held on by 6 clips (rounded lid), relatch the clips.
13. Reattach the flex hose to the RESPA outlet, ensuring that contamination of tubing, HVAC, and cabin air does not occur.  
**NOTE:** Take care not to overtighten clamps, as this could cause "crush" damage.

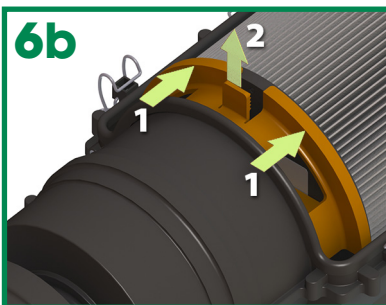
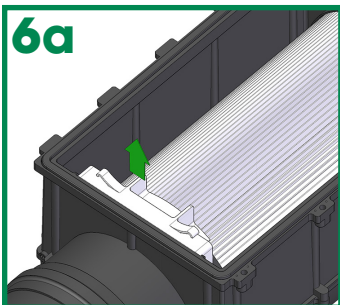
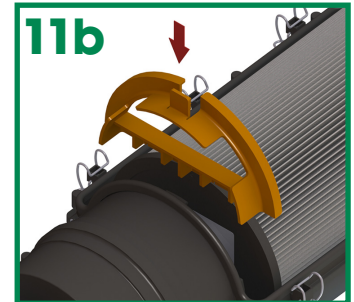
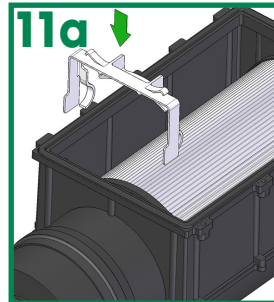

**Replace filter only!**  
**Do not clean or re-use filters.**  
Re-using filters can create health hazards!  
**Replace with Sy-Klone filters only.**  
Order from your dealer or from Sy-Klone.

## SYSTEM CLEANING:

**When changing the filter, it is a good time to inspect and clean the whole system.**

1. The machine should be off.
2. Remove any loose dirt from RESPA unit before removing any components.
3. Prior to removing filter, remove the hose from RESPA unit outlet and plug with rag, or equivalent, to prevent dirt from entering hose. For recirculation systems, also remove hose from inlet and plug.
4. Use rag to wipe/clean outside of RESPA unit.
5. Bag and seal used filter element and dispose of according to local regulation. See previous section on filter replacement for details.
6. Remove rain cap and inspect air inlet. Clean if necessary, instructions listed below.
7. Inspect ejection ports and clear if necessary, instructions listed below. (Fresh air system only.)
8. Vacuum or wipe out filter cavity.
9. Apply power to unit. Check the rotation of the fan blade. Looking into the inlet, the fan blade should be spinning in a counter clockwise direction. (Fresh air system only). **DO NOT INSERT ANY OBJECTS INTO FAN/MOTOR HOUSING.**
10. Before installing the new filter, apply a small amount of lubricant, supplied with filter, to filter's o-ring.
11. Reassemble RESPA system and check for leaks and proper operation. Take care not to overtighten clamps, as this could cause "crush" damage.

### WARNING:

**When cleaning equipment, care should be taken to prevent water from entering RESPA Units or Ejection Ports! Never use compressed air or water to clean RESPA. Instead, use a rag to wipe/clean.**

## RAIN CAP INSPECTION AND CLEANING:

**The rain cap should be regularly inspected to make sure that it is free from debris.**

1. Remove the rain cap and inspect the air inlet.
2. If debris is detected remove cap and clean out debris.
3. Replace the rain cap, making sure that the clamp which holds the rain cap in place is snug. Take care not to overtighten clamp, as this could cause "crush" damage.

## EJECTION PORT INSPECTION AND CLEANING:

**The round ejection ports may become impacted with debris. While this is a rare occurrence it is possible and will dramatically compromise the precleaning ability of the Powered Precleaner.**

**If dirt is not being ejected out of the Fresh Air Unit ejection ports, perform the ejection port inspection regardless of the filter change interval.**

1. When changing the filter also inspect the ejection ports in the Powered Precleaner .
2. Make sure that the precleaner is turned off and that the key is out of the ignition. Using needle nose pliers reach up into each ejection port and remove the debris. Once all major obstructions have been removed turn on the precleaner by turning the key to the on position. When the Powered Precleaner turns on the remaining debris will be ejected out of the ejection port.
3. If you can still see debris in the ejection port, repeat step 2, or try blowing out with compressed air.

## FIELD SERVICE PARTS

**Rain Cap** RE0004-RC

**Filters:** FEFF005 MERV 16 / F9 Filter  
FEFF004 HEPA H-13/ISO35H Filter

**RESPA-SD<sup>2</sup> specific parts (unit with rounded lid):**

REA0141 Replacement Lid  
REA0142 Replacement Lid Gasket Seal  
REA0143 Replacement Filter Retention Clip

**RESPA-SD specific parts (unit with flat lid):**

RE0004-L-SYK Replacement Lid  
RE0004-G Replacement Lid Gasket Seal  
RE0004-L-LHW Replacement Lid Fasteners

**There are no service parts for the powered precleaner, and disassembling the product in any way voids the warranty.**

## TECHNICAL SUPPORT

**Contact your Dealer for support or**

**Sy-Klone International**

Tel: +1 (904) 448-6563

FAX: +1 (904) 448-6626

email: support@sy-klone.com

[www.sy-klone.com](http://www.sy-klone.com)

**SY-KLONE**<sup>®</sup>  
INTERNATIONAL